

Convenient Installation

Zareba Product Overview

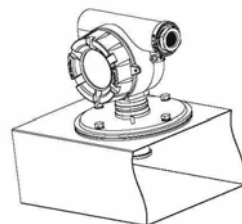

- **Removable display module**
 - Enables unhindered access to terminals
- **Wall mount & pole mount**
 - Bracket included with every unit
- **Collecting cone**
 - Replaces weatherproof cover
 - Includes inlet for remote gassing
- **Duct mount arrangement**
 - Clamping ring for duct
 - Removable plate attaches to ring
 - Detector attaches to the plate
 - External inlet for remote gassing

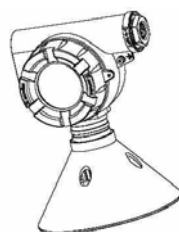
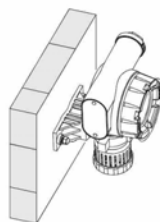
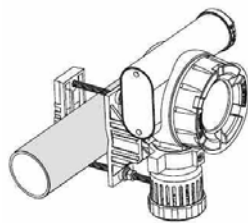
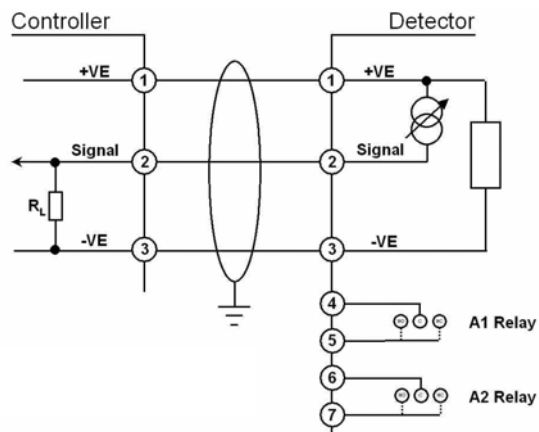

3 Wire 4-20mA (Source) + Relays

**Easy to install, use and
maintain in a variety
of installations**