

Convenient Installation

Zareba Product Overview

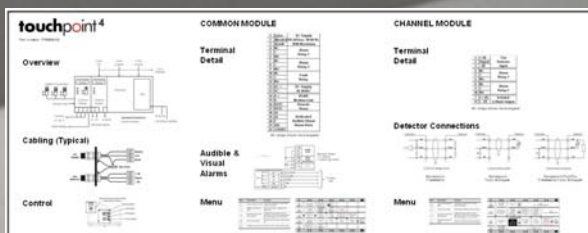

Channel Module		
1	VE	Gas
2	Signal	Detector
3	VE	Input
4	INC	Alarm
5	IC	Relay 1
6	INO	Relay 2
8	INC	Alarm
9	IC	Relay 2
10	INO	Isolated
7	VE	Isolated
11	VE	4-20mA Output

All relays shown de-energized

- **Wall mounting bracket supplied**
 - Used as a template for drilling
 - Reduces risk of damage to controller
 - Controller 'locked' to bracket after fitting
- **Pre-formed knockouts in gland plate**
 - M20 & 3/4" NPT clearance as standard
 - No need for drilling of enclosure (swarf)
- **Front cover may be latched open**
 - Unhindered access to terminals
 - Keeps both hands free for wiring
- **Large terminal compartment**
 - Plenty of space to complete installation
- **Local instructions included on label**
 - mA version shown

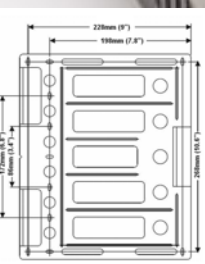

Dedicated Alarm Drives

Zareba Product Overview



- **Powered alarm outputs**
 - No auxiliary supply required
- **0Vdc switching**
 - Suitable for wide range of suppliers
 - Enables most cost effective offering
- **Comprehensive product range**
 - Audible alarms
 - Visual alarms
 - Audiovisual alarms
 - Status indicators

} Safe & Hazardous Area Approved
- **Approved equipment included within the Zareba range**

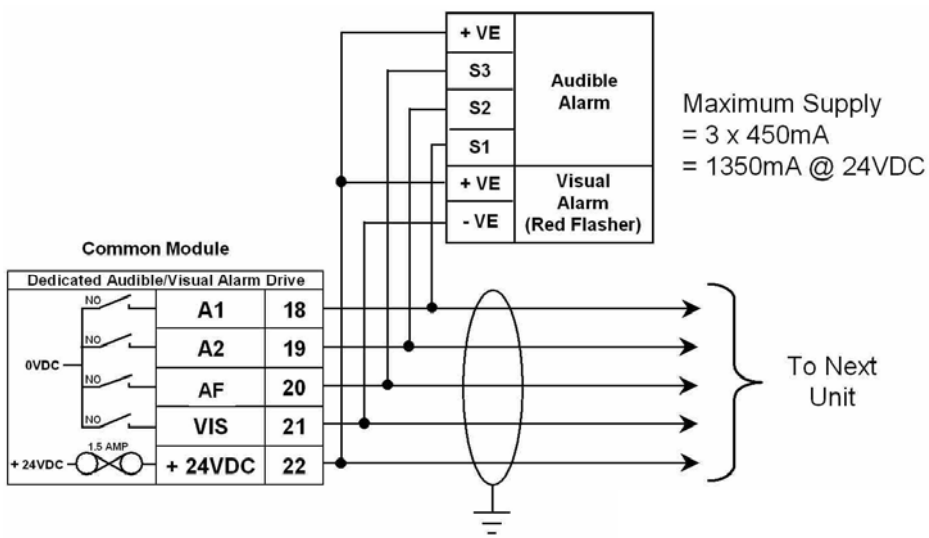

Common Systems Approach

Zareba Product Overview

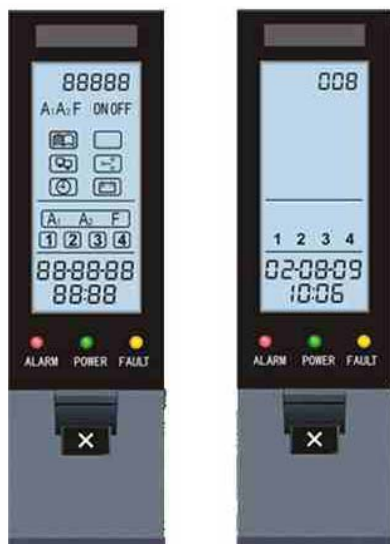

Common Module



Channel Module

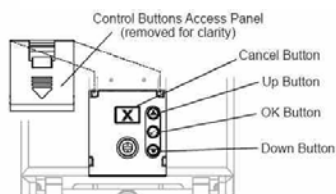

- **Common design & operation to Touchpoint 1**
 - Split information between Common and Channel Modules
 - Learn one, learn them all
- **Powder blue backlit display**
 - Excellent contrast and viewing angle
 - Can be seen in dark, poorly lit environments
- **Status indication clearly communicated**
 - Address, gas, range, units, gas reading, bar graph, alarm levels
 - Power, alarm & fault icons with LEDs and audible alarm
- **Event recording included as standard**
 - Enables review of alarm, fault and power history
 - Time and date of on/off operation logged
- **Simple pushbutton operation**
 - Normal operation: 'X' = 'Self Test' or 'Accept/Reset'
 - Configuration via 'hidden' pushbuttons & icon menu
- **Fully user configurable**
 - Gas, range, units, alarm levels
 - Relays normally energised/de-energised, latching/non-latching

Small to Medium Systems

Zareba Product Overview

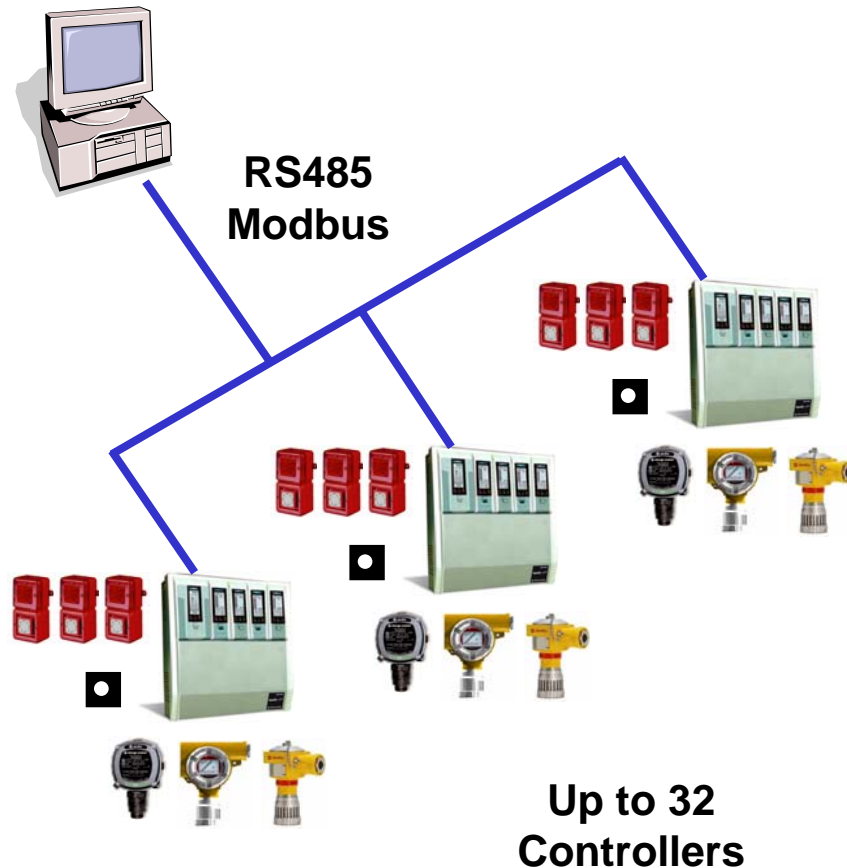

- **Local, self contained systems**
 - Detection, alarm and control
- **Supervision via central station**
 - Standard equipment and software
 - Outside Zareba scope of supply

Provides scope for larger system solutions to customers